

KENDRIYA VIDYALAYA JALIPA CANTT

2nd Pre-Board Examination, 2009-10

Subject: Computer Science (083)

Class: XII

Time Allowed: 3 Hours

Max. Marks: 70

Instructions:

- i) All questions are compulsory and so attempt all.
- ii) Programming language: C++.
- iii) Please check that this question paper contains 7 questions in 7 pages.
- iv) Please write down the complete serial number of the question before attempting it.

1). (a) What does Overloaded function mean? Write its significance in context of C++. **2**

(b) Name the header file required for successful compilation of the given code: **1**

```
int main( )
{
    char str[20];
    cout<<fabs(-34.776);
    cout<<“\n Enter a string:”;
    cin.getline(str,20);
    return 0;
}
```

(c). Rewrite the following program after removing all the syntactical errors underlining each correction.(if any): **2**

```
#include<iostream.h>
Struct NUM
{
    int x=10;
    float y;
}A, *p;
void main( )
{
    p=A;
    cout<<\nInput Integer::;
    cin>>A.x;
    cout<<“\nInput any number:”;
    cin<<y.A;
}
```

(d) Write the output of the following program segment: **3**

```
#include<iostream.h>
void main()
{
    int A[]={ 12,18,20, 35,40};
    int *p=A;
    while(*p<30)
    {
        if(*p%3!=0)
            *p=*p+5;
        else
            *p=*p+2;
        p++;
    }
    for(int j=0;j<=4;j++)
```

```

    {
        cout<<A[j]<<"*";
        if(j%3==0)
            cout<<endl;
    }
    cout<<A[4]*3<<endl;
}

```

(e). Write the output of the following program segment:

2

```

#include<iostream.h>
#include<string.h>
#include<ctype.h>
void main()
{
    char *ch = "Our 3 IdiotS";
    for(int p=0;p<strlen(ch);p++)
        if(isdigit(ch[p]))
            ch[p] = '-';
        else if(isupper(ch[p]))
            ch[p] = tolower(ch[p]);
        else if(islower(ch[p]))
            ch[p] = toupper(ch[p+1]);
        else if(ch[p] == ' ')
            ch[p] = '*';
    cout<<ch<<endl;
}

```

(f) In the following program, find the correct possible output(s) from the options:

2

```

#include<iostream.h>
#include<stdlib.h>
void main( )
{
    randomize( );
    int p=99,q=999;
    int x=random(3)+4;
    int y=random(2)+2;
    for(int i=0;i<x;i++)
        cout<<'#';
    cout<<p<<'-'>;
    for(i=0;i<y;i++)
        cout<<'@';
    cout<<q<<endl;
}

```

- i) ##99-@999
- ii) ##99-@@999
- iii) #####99-@@999
- iv) #####99-@@999

2. (a) Differentiate between Private and Protected members of class in context of inheritance using C++.

2

(b). Define a class **Society** with the following specifications.

4

Data members :

Private Members :

society_name char (30)

house_no integer

no_of_members integer

flat char(10)

income float

Member Functions:

Public members:

A **constructor** to assign initial values of society_name as “Mahavir Nagar”, flat as “A Type”, house_no as 56, no_of_members as 6, income as 50000.

input() – to read data members.

alloc_flat() – To allocate flat according to income

income \geq 50000 - Flat “ A Type”

income \geq 25000 and income $<$ 50000 - Flat “ B Type”

income $<$ 25000 - Flat “ C Type”

show() – to display all details.

(c) Consider the following declarations and answer the questions given below:

4

```
class olympics
{
    int no_of_events;
    char country_name[25];
protected:
    void initialize();
public:
    olympics();
    void olympicsentry();
    void olympicsdisp();
};
class outdoorgame : public olympics
{
    char eventname[20];
    int eventcode;
public:
    outdoorgame();
    outdooreentry();
    void outdoordisp();
};
class hockey : public outdoorgame
{
    int no_of_players;
    char venue[25];
public:
    hockey();
    void hockeyentry();
    void hockeydisp();
};
```

(i) Which type of inheritance is shown in the above example?

(ii) How many bytes will be required by an object of the class hockey?

(iii) Write names of all the data members accessible from member functions of the class hockey?

(iv) Write names of all the member functions, which are accessible from an object of the class outdoorgame?

(d). Answer the questions (i) and (ii) after going through the following class. 2

```
class Factory
{ private:
    char Name[30];
    int worker;
public:
    Factory() //function 1
    { strcpy(Name,"Blank");
      worker=0; }
    void Details() //function 2
    { cout<<Name<<endl<<worker<<endl; }
    Factory(char *Fact_name, int No); //function 3
    Factory(Factory &F); // function 4
};
```

i). In OOP, what is *function 4* referred as? Also write its complete definition and a statement which will invoke this function?

ii). In OOP, which concept is illustrated by *function 1, function 3 & function 4* together? Also write a statement which will invoke *function 3*?

(3). (a) An array MAT[20][12] is stored in the memory column wise with each element occupying 2 bytes of memory. Find out the base address and the address of element MAT[15][10], if the location of MAT[2][4] is stored at the address 1000. 4

(b). Write function in C++ which accepts an integer array and size as arguments and assign values into a 2D array of integers in the following format: 4

If the array is 1, 2, 3, 4, 5, 6

The resultant 2D array is given below

```
1 2 3 4 5 6
1 2 3 4 5 0
1 2 3 4 0 0
1 2 3 0 0 0
1 2 0 0 0 0
1 0 0 0 0 0
```

If the array is 1, 2, 3

The resultant 2D array is given :

```
1 2 3
1 2 0
1 0 0
```

(c) Write a function to perform *PUSH* operation in a *dynamically allocated stack* containing name and registration number of students. Also declare the relevant structure/class and pointers. 4

(d) Write the equivalent postfix notation for the following: 2

$A - B + C * D ^ E * G / H$

(4). (a) Observe the program segment given below carefully and fill the blanks marked as Statement 1 and Statement 2 using seekp() and seekg() functions for performing the required task. 1

```
#include <fstream.h>
class Item
{
    int Ino; char Item[20];
```

```

public:
    //Function to search and display the content from a particular //record number
    void Search(int );
    //Function to modify the content of a particular record number
    void Modify(int);
};
void Item::Search(int RecNo)
{
    ifstream File;
    File.open("STOCK.DAT",ios::binary|ios::in);

    _____
    //Statement 1
    File.read((char*)this,sizeof(Item));
    cout<<Ino<<"=="<<"<<Item<<endl;
    File.close();
}
void Item::Modify(int RecNo)
{
    ifstream File;
    File.open("STOCK.DAT",ios::binary|ios::in|ios::out);
    cout>>Ino;cin.getline(Item,20);

    _____
    //Statement 2
    File.write((char*)this,sizeof(Item));
    File.close();
}
}

```

(b) Write a function in C++ to count the number of spaces/blanks present in a text file "TOUR.DAT". 2

(c). Write a function in C++ to search for a Pcode from a binary file "PRODUCT.TXT", assuming the binary file is containing the objects of the following class. 3

```

class PRODUCTS
{
    int Pcode;
    char Pname[20];
    float Price;
public :
    void getproducts()
    {
        cin>>Pcode>>Pname>>Price;
    }
    void showproducts()
    {
        cout<<Pcode<<Pname<<Price<<endl;
    }
    int *getproduct()
    {
        return Pcode;
    }
};

```

(5). (a) What do you understand by DOMAIN and Degree of a RELATION? 2

(b). Consider the following tables CUSTOMER and MOBILE. Write SQL commands for the statements (i) to (iv) and give outputs for SQL queries (v) to (viii) 6

TABLE : CUSTOMER

ID	Cname	Activation_date	Validity (in days)	Amount	Connection
101	Preeti	04-Jun-09	365	330	Hutch
102	Sumit	12-Feb-08	60	180	Airtel
103	Aamir	14-May-09	180	250	Aircel
104	Mukul	30-Jan-08	30	100	Bsnl
105	Ambani	08-Mar-07	365	310	Reliance
106	Rani	02-Apr-09	90	210	Airtel
107	Vijay	12-Sep-09	60	150	Bsnl

TABLE : MOBILE

ID	Make	Model_No
101	Nokia	N76
102	LG	RD3500
104	Nokia	E61
105	Sony	K310i
107	Motorola	W756i

- (i) To display the records of those customer who take the connection of Bsnl and Airtel in ascending order of Activation date.
- (ii) To decrease the amount of all customers of Reliance connection by 500.
- (iii) Create a view called ITSECTOR, which contains Cname, Validity and Connection from CUSTOMER table whose Activation date is after 14-May-09.
- (iv) To display the ID and Cname from table Customer and Make from table Mobile, with their corresponding matching ID.
- (v) select Cname , Make form Customer, Mobile where Customer.ID = Mobile.ID;
- (vi) select Connection , sum(Amount) from Customer group by Connection ;
- (vii) SELECT COUNT(DISTINCT Make) FROM Mobile; .
- (viii) SELECT AVG(Amount) FROM Customer where Validity >= 180;

(6). (a) State and verify *Distributive law* algebraically. 2

(b) Write the equivalent Boolean expression for the following logic circuit: 2

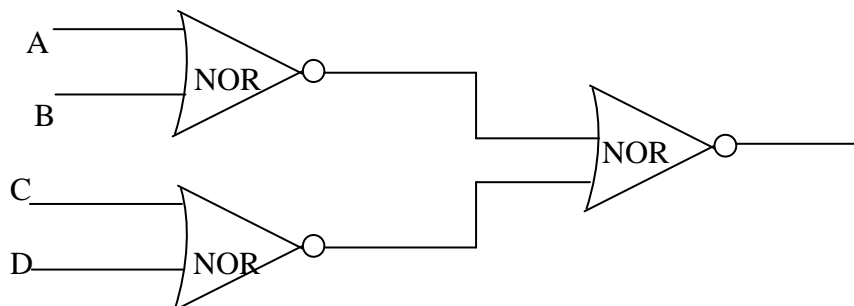

(c) Write the equivalent POS expression of following SOP form 1
 $F(x,y,z) = \sum (0,2,4,6)$

(d) Reduce the following Boolean expression using K-map. 3
 $F(A,B,C,D) = \sum(0,1,2,4,5,6,8,10)$

- (7). (a) What is a Gateway? 1
 (b) Expand the following terminologies with respect to Networking: 2
 i) XML ii) NIC iii) W3C iv) URL.
 (c) Give one advantage of GSM mobile technology? 1
 (d) Differentiate between *freeware* and *shareware*.? 1
 (e) What is cyber law? 1
 (f) Global Village Enterprises has following four buildings in Hyderabad city. 4

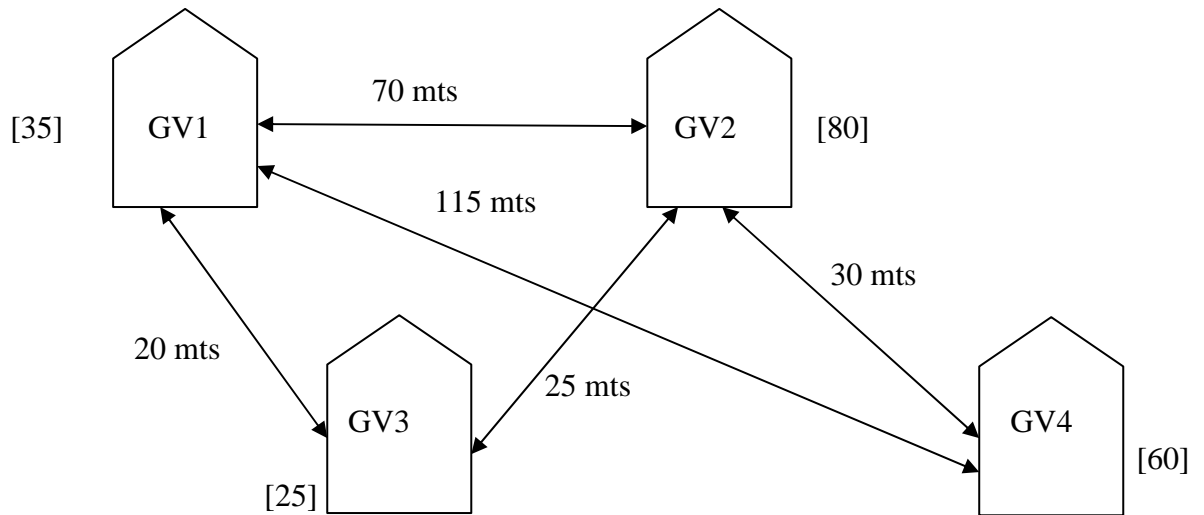

↔ Shows Distance
 [] Shows Number of Computer

Computers in each building are networked but buildings are not networked so far. The company has now decided to connect building also.

- (i) Suggest a topology and its cable layout for these buildings.
- (ii) The company also wants to make available shared Internet access for each of the buildings. How can this be achieved?
- (iii) Which of the following communication media, will you suggest to be procured by the company for connecting their local offices in Hyderabad for very effective and fast Communication?
 - Ethernet Cable
 - Optical Fiber
 - Telephone Cable
- (iv) The company wants to link its headoffice in GV2 building to its another office in Japan.
 - (a) Which type of transmission medium is appropriate for such a link?
 - (b) What type of network would this connection result into?



**“You have one thing common with successful people – “a 24 hour day”.
 It’s how you see it that makes the difference”.**

All the Best for Board Exam 2010.

KENDRIYA VIDYALAYA JALIPA CANTT

2nd Pre-Board Examination, 2009-10

Subject: Computer Science (083)

Class: XII

(Marking Scheme)

Time Allowed: 3 Hours

Max. Marks: 70

Q.No	Answer	Marks
1) a.	A function name having several definitions that are differentiable by the number or types of their arguments is known as overloaded function. void area (int side); void area (int l, int b); It implements polymorphism & also reduces number of comparisons in a program and makes program run faster.	2 (1 Mark for correct definition & 1 mark for significance)
1) b.	iostream.h, math.h	1 (½ Mark for mentioning name of each header file)
1) c.	<pre>#include<iostream.h> struct NUM { int x; float y; }A, *p; void main() { cout<< "\nInput Integer:"; cin>>A.x; cout<< "\nInput any number:"; cin >> A.y; }</pre>	2 (½ Mark for mentioning each error)
1) d.	14* 20*25*35* 40*120	3 (1 Mark for each correct line of output)
1) e.	oR *-*iIOTSs	2 (½ Mark for each triplicate)
1) f.	iii) and iv)	2 (1 Mark for each correct option)
2) a.	Both are not accessible outside a class and can accessed inside a class by the member functions & friend functions of that class only. Private members can not be inherited further but protected members can be inherited further.	2 (2 Mark for correct difference)
2) b.	<pre>class Society { private: char society_name[30], flat[10]; int house_no, no_of_members; float income; public: Society() { strcpy(society_name, "Mahavir Nagar"); strcpy(flat, "A Type");</pre>	4 (½ Mark each for data members and constructor) (1 Mark for each function definition)

	<pre> house_no= 56; no_of_members= 6; income= 50000; } void input() { gets(society_name); cin>> house_no>> no_of_members>> income; } void alloc_flat() { if (income>= 50000) strcpy(flat, "A Type"); else if (income>= 25000) strcpy(flat, "B Type"); else strcpy(flat, "C Type"); } void show() { cout<<society_name<<flat<<house_no<< no_of_members << income; } }; </pre>	
2) c.	<p>i) Multilevel inheritance ii) 76 bytes iii) Data members- no_of_players, venue. iv) Member functions- outdoorentry(), outdoordisp(), olympicsentry(), olympicsdisp().</p>	<p>4 (1 Mark for each correct answer.) No marks to be given for partial answers</p>
2) d.	<p>i) Funtion 4- Copy Constructor Definition- Factory(Factory & F) { strcpy(Name, F.Name); worker= F.worker; } Calling- Factory ob1; Factory ob2 = ob1; OR Factory ob2 (ob1); ii) Constructor Overloading Factory ob1("MRF", 2500);</p>	<p>2 (1 Mark for correctly answering to each part.)</p>
3) a.	<p>Given, W=2 N_r =20 N_c=12 Address(MAT[2][4])=1000 Column Major Formula: Address (MAT[I][J]) = B + W [(I - L_r) + N_r (J- L_c)] Address (MAT[2][4])= B + 2 [(2 - 0) + 20 (4- 0)] 1000 = B + 2 [2 + 80] B= 836 Address (MAT[15][10])= 836 + 2 [(15 - 0) + 20 (10- 0)] =836 + 2 [15 + 200] = 1266</p>	<p>4 (½ Mark for correct formula/substitution of values in formula) (1½ Mark for correctly calculating Base Address) (2 Mark for correctly calculating address of desired location)</p>
3) b.	<pre> void input (int a[],int N) { int b[N] [N]; for (int i=0;i.<N;i++) </pre>	<p>4 (½ Mark for function header with desired parameters)</p>

	<pre> { for (int j=0;j<N;j++) { if((i+j)>=N) b[i][j]=0; else b[i][j]=a[j]; cout<<b[i][j]<<'t'; } cout<<endl; } } </pre>	<p>(½ Mark initialising counters) (1 Mark for correct formation of loop) (1 Mark for correct comparison of elements) (1 Mark for transferring remaining elements in resultant array)</p>
3) c.	<pre> struct NODE { char name[20]; int regno; NODE *Next; }; void Push(Node * Top) { NODE *ptr = new NODE; cin>>ptr->regno; gets(ptr->name); ptr->Next=NULL; if (Top == NULL) Top= ptr; else { ptr->Next = Top; Top= ptr; } } </pre>	<p>4 (½ Mark for appropriate function header) (½ Mark for declaring a Temporary pointer - ptr) (1 Mark for new operation) (1 Mark for ptr->Next to Top) (1 Mark for assigning Top as Temp)</p>
3) d.	<p> $((A - B) + (((C * (D ^ E)) * G) / H))$ $(AB- + (((C * DE^)* G)/H))$ $(AB- + ((CDE^* * G)/H))$ $(AB- + (CDE^*G* / H))$ $(AB- + CDE^*G*H/)$ $(AB- CDE^*G*H/+)$ </p>	<p>2 (½ Mark for each correctly evaluating parenthesis)</p>
4) a.	<pre> File.seekg(RecNo*sizeof(Item)); //Statement 1 File.seekp(RecNo*sizeof(Item)); //Statement 2 </pre>	<p>1 (½ Mark for each correct statement)</p>
4) b.	<pre> void CountSpaces() { ifstream fin; fin.open("TOUR.DAT"); int count=0; char ch; while (!fin.eof()) { fin.get(ch); if (ch= " ") { count++; } } cout<<"No of spaces="<<count; fin.close(); } </pre>	<p>2 (½ mark for correct syntax of function header and opening the file in 'in' mode) (½ mark for reading content from file) (½ mark for correct condition for searching) (½ mark for displaying the result)</p>

4) c.	<pre> void ProductSearch() { ifstream fin; fin.open("PRODUCT.TXT",ios::binary ios::in); PRODUCTS P; int p_code, Found=0; cout<<"Enter Product Code to be search:"; cin>> p_code; while (!fin.eof()) { fin.read((char*)&P,sizeof(P)); if (P.getproduct()= p_code) { P.Showproducts(); Found++; } } if (Found==0) cout<<"Sorry! Product not found!!!"<<endl; fin.close(); } </pre>	<p>3 (½ mark for correct syntax of function header and body) (½ mark for opening the file in 'in' mode) (½ mark for reading content from file into the object of P) (½ mark for appropriate loop) (½ mark for correct condition for searching) (½ mark for displaying the content of the object)</p>																								
5) a.	<p>Domain- A pool of values from which actual values are derived for a particular column. Degree- The number of columns in a relation.</p>	<p>2 (1 mark for each correct definition)</p>																								
5) b.	<p>i) select * from Customer where Connection= 'Airtel' or Connection= 'bsnl' order by Activation_date; ii) update customer set amount= amount – 500 where Connection= 'Reliance'; iii) create view ITSECTOR as select cname, validity, connection from customer where Activation_date> '14-May-09'; iv) select customer.ID, cname, make from customer, mobile where customer.ID= mobile.ID;</p> <table data-bbox="304 1496 767 1715"> <tr> <td>v) <u>cname</u></td> <td><u>make</u></td> </tr> <tr> <td>Preeti</td> <td>Nokia</td> </tr> <tr> <td>Sumit</td> <td>LG</td> </tr> <tr> <td>Mukul</td> <td>Nokia</td> </tr> <tr> <td>Ambani</td> <td>Sony</td> </tr> <tr> <td>Vijay</td> <td>Motorola</td> </tr> </table> <table data-bbox="304 1720 767 1939"> <tr> <td>vi) <u>connection</u></td> <td><u>sum(amount)</u></td> </tr> <tr> <td>Hutch</td> <td>330</td> </tr> <tr> <td>Airtel</td> <td>390</td> </tr> <tr> <td>Aircel</td> <td>250</td> </tr> <tr> <td>Bsnl</td> <td>250</td> </tr> <tr> <td>Reliance</td> <td>310</td> </tr> </table> <p>vii) <u>count (distinct make)</u> 4 viii) <u>avg(amount)</u> 296.66</p>	v) <u>cname</u>	<u>make</u>	Preeti	Nokia	Sumit	LG	Mukul	Nokia	Ambani	Sony	Vijay	Motorola	vi) <u>connection</u>	<u>sum(amount)</u>	Hutch	330	Airtel	390	Aircel	250	Bsnl	250	Reliance	310	<p>6 (1 mark for each correct query) (½ mark for each correct output)</p>
v) <u>cname</u>	<u>make</u>																									
Preeti	Nokia																									
Sumit	LG																									
Mukul	Nokia																									
Ambani	Sony																									
Vijay	Motorola																									
vi) <u>connection</u>	<u>sum(amount)</u>																									
Hutch	330																									
Airtel	390																									
Aircel	250																									
Bsnl	250																									
Reliance	310																									

6) a.	i) $X(Y+Z) = XY + XZ$ ii) $X + YZ = (X+Y)(X+Z)$ $RHS = XX + XZ + YX + YZ$ $= X + XZ + XY + YZ$ [XX= X, Idempotence Law] $= X + XY + XZ + YZ$ [YX= XY, Commutative Law] $= X(1+Y) + XZ + YZ$ $= X \cdot 1 + XZ + YZ$ [1+Y= 1, Property of 0 and 1] $= X(1+Z) + YZ$ $= X \cdot 1 + YZ$ [X.1= X, Property of 0 and 1] $= X + YZ$ $= LHS$	2 (1 mark for stating the correct law) (1 mark for the appropriate verification using algebraic method)
6) b.	$((A+B)' + (C+D)')'$	Full 2 marks for obtaining the correct Boolean Expression for the Logic Circuit
6) c.	$F(x,y,z) = \sum(0,2,4,6)$ Equivalent POS, $F(x,y,z) = \pi(1,3,5,7)$ $M_1 = 001 = (x + y + z')$ $M_3 = 011 = (x + y' + z')$ $M_5 = 101 = (x' + y + z')$ $M_7 = 111 = (x' + y' + z')$ $F(x,y,z) = (x + y + z') \cdot (x + y' + z') \cdot (x' + y + z') \cdot (x' + y' + z')$	(1 mark for correct POS representation)

6) d.

	$A'B'$	$A'B$	AB	AB'
$C'D'$	1	1		1
$C'D$	1	1		
CD				
CD'	1	1		1

$F(A,B,C,D) = A'C' + A'D' + B'D'$

(1 mark for correctly drawing K-Map with 1s represented on right places)
 (1 mark for minimizing each Quad)
 (1 mark for writing the complete Boolean Expression)

7) a.	Gateway is a network device that connects dissimilar networks with completely different structures.	1 Mark for correct definition
7) b.	XML- eXtensible Markup Language NIC- Network Interface Card W3C- World Wide Web Consortium URL- Uniform Resource Locator	2 (½ Mark for each correct expansion)
7) c.	GSM means Global System for Mobile communications that is a leading cellular system which uses SIM cards and narrowband TDMA which allows multiple simultaneous calls on a same radio frequency.	1 Mark for correct definition
7) d.	Freeware are the software which available free of cost and allows copying and further distribution, but not modification as source code not available. Shareware are the software which is available with right to redistribute copies, but often after a certain period of time a license fee should be paid.	1 (½ Mark for each correct definition)

7) e.	Cyberlaw refers to all the legal and regulatory aspects of Internet and the World Wide Web.	<i>1 Mark for correct definition</i>
--------------	---	--------------------------------------

7) f. (i) Layout Option 1: Star topology

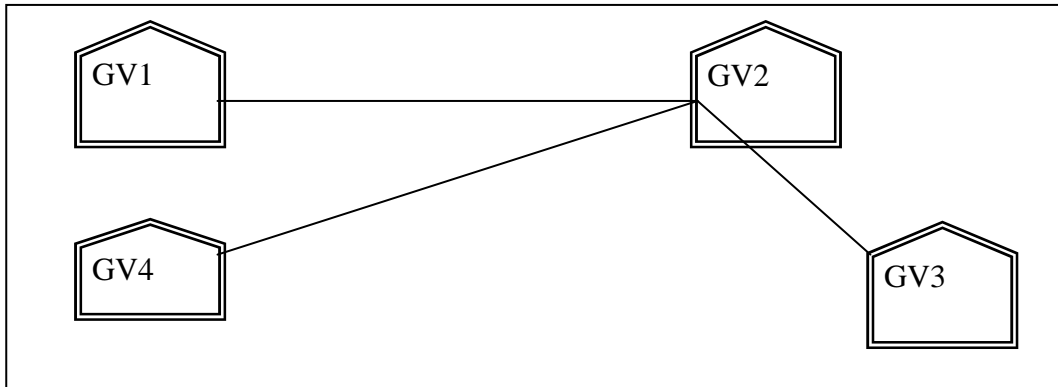

Layout Option 2: Bus topology

Since the distance between GV3 and GV2 is quite short

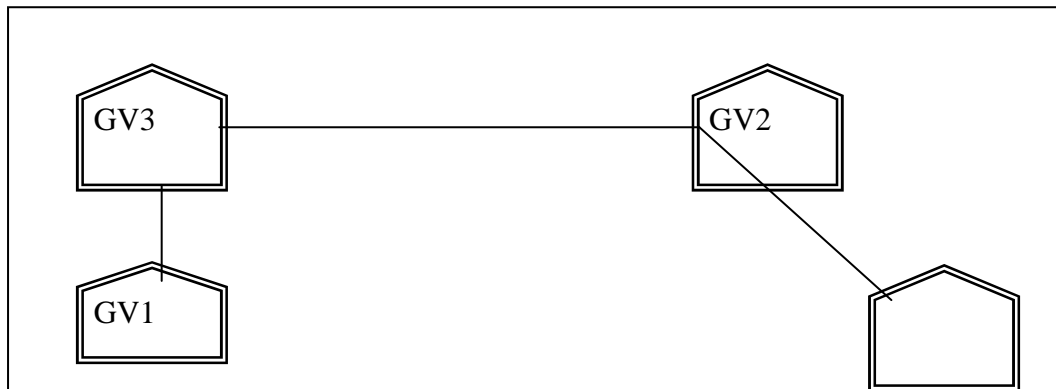

(1 mark for any of the above shown Layout)

7) f.	ii) Dialup/ Broadband Connection	<i>1 mark for correct answer</i>
	iii) Optical fiber	<i>1 mark for correct answer</i>
	iv) a) Unguided media- Satellite b) WAN- Wide Area Network.	<i>1/2 mark for each correct answer</i>